



Pm Trac multipurpose tractor *Generation 38*

At the ZLF 2004 in Munich, Pfanzelt set standards with the presentation of the Pm Trac multipurpose tractor. The development trend - using a tractor chassis from the large-scale production to the completely own tractor chassis - makes the Pm Trac unique. Among other things, the continuously variable and power-split transmission variaDRIVE - a proprietary development for Pfanzelt forestry machines - offers new possibilities and contributes its share to the motto of the new Pm Trac generation: *Versatility is its strength - working and operating comfort its virtue.*

The Pm Trac multipurpose tractor of the *Generation 38* is optimised for combined use in agriculture, forestry, and landscaping thanks to its unique vehicle concept.

The core of the Pm Trac machine concept includes the centrally located large tractor cab and the central superstructure space above the rear axle. Fast and flexible adaptation to different working conditions is based on the Pfanzelt System Attachment (PSA).

Convincing technical details:

- Six-cylinder engine with 205, 253, and 292 hp respectively, Cleanfix changeover fan, and 400-litre fuel tank
- Power-split, continuously variable gear unit variaDRIVE up to 50 km/h (max. driving speed with reduced engine speed)
- Hydraulic system with 160 l/min at 210 bar (optional 200 l/min as well as additional power pack directly at the power take-off of the gearbox)
- New machine control software for complete customisation of the operation to the driver
- Pneumatically suspended XXL comfort cab with optimum all-round visibility and rotating operator stand
- Support frame with 4 variable mounting and attachment areas for the heaviest implements
- Pfanzelt system receptacle: Toolless quick-change console for crane and cable winch

Technical specs ► Page 147





Pm Trac multipurpose tractor live in action.
[youtube.com/pfanzeltTV](https://www.youtube.com/pfanzeltTV)

Pm Trac multipurpose tractor

Fields of application

Designed for forestry applications, the Pm Trac multipurpose tractor is also universally applicable.

Forestry

Forwarding of long and short timber

For long and short timber forwarding, the rear mounting space, which is located directly above the rear axle, is used for mounting the cable winch and forest crane. Depending on the area of application, a rear crane (low column) or a loading crane (high column) can be set up with a favourable centre of gravity.

With Pfanzelt's system mount, the different types of cranes and the forestry winches can quickly and easily be assembled and disassembled.

Versatility in forestry

In forestry, the Pm Trac is not only convincing in classic forwarding use. In addition to the use with a forestry mulcher for area cultivation, the Pm Trac can also show its full potential with an energy woodcutting gripper. When used with a felling unit or a mulching head on the forestry crane which requires a higher hydraulic power, a powerful auxiliary hydraulic system can be installed.

The Pm Trac's performance spectrum also includes the use of a shredder. In addition to shredders with their own engine, shredders driven by the tractor's PTO shaft can also be combined. The rear PTO of the Pm Trac is still accessible even with the crane and winch mounted.





Municipality and landscaping

Thanks to the rear attachment space with rear power lift, other implements such as mower spreaders can also be driven in combination with an additional edge mower or area mulcher.

The Pfanzelt System mount serves as a support frame for the Pm Trac. The extreme forces involved when using heavy-duty forwarding cranes or mower implements are absorbed by the

supporting frame and dissipated in a controlled way.

The Pm Trac is also the ideal helper in landscape maintenance.

For municipal use, a municipal coupling plate can be installed instead of a front hydraulic system.



Agriculture

As soon as the forestry implements have been removed, the tractor can be used for agricultural purposes without any additional conversion measures, as neither the rear power lift nor any other relevant components are modified for forestry operation. In addition to the rear and front attachment areas, front loader consoles are also part of the multiurpose tractor's concept.



Pm Trac *Generation 38*

Technical details at a glance:

1

Perfect feeling of space in the XXL cabin thanks to the largely dimensioned **air conditioning with automatic control**.

2

Comfortable, air-suspended cab for two persons with **air-suspended driver's seat** and large passenger seat.

3

7 m² glass surface and a **340° electrically rotating operator's platform** for an optimal view of the working environment.

4

Plenty of storage space for chainsaw, fuel canister, and tools for forestry.

5

High-torque and economical 6-cylinder engine with **205, 253, or 292 hp**.

6

CLEANFIX reversing fan for radiator cleaning with optimum cooling and considerable fuel savings.

7

Front hydraulics with optional front PTO.

8

Quick and easy **removable fenders** and lighting equipment for road travel.

9

The thrust tube front axle with **automatic blocking** for crane work enables perfect standing.

10

12 work lights on the cab roof provide optimum illumination of the working environment.

11

A well thought-out system of **protected hoses** on the complete crane ensures minimum downtime.

12

The Power Link System (toggle joint connection) guarantees maneuverable crane operation, greater reach, and more lifting power.

13

Additional **crane floodlights** turn night into day and always light up the gripper area.

14

The **telescopic cylinder** is internally mounted, protecting it from damage.

15

Equipped as standard with a powerful **flange rotor** and on request also with a **double pendulum brake**.

16

PSA (Pfanzelt system mount) for the attachment of a cable winch, forwarding or loading crane as well as mowing booms.

17

Professional and powerful **Double drum gear winch** with two times 6 or 8 t pulling force.

18

Freely accessible rear power take-off shaft, trailer rail, rear hydraulics even with mounted crane (without pole shield).

19

EU Tier V: Exhaust aftertreatment with SCR technology, AdBlue injection, and a particle filter.

20

Safe working via an **active standstill control** is provided by the continuously variable, power split transmission.



Pm Trac multipurpose tractor *Generation 38*

Technical details that will convince you

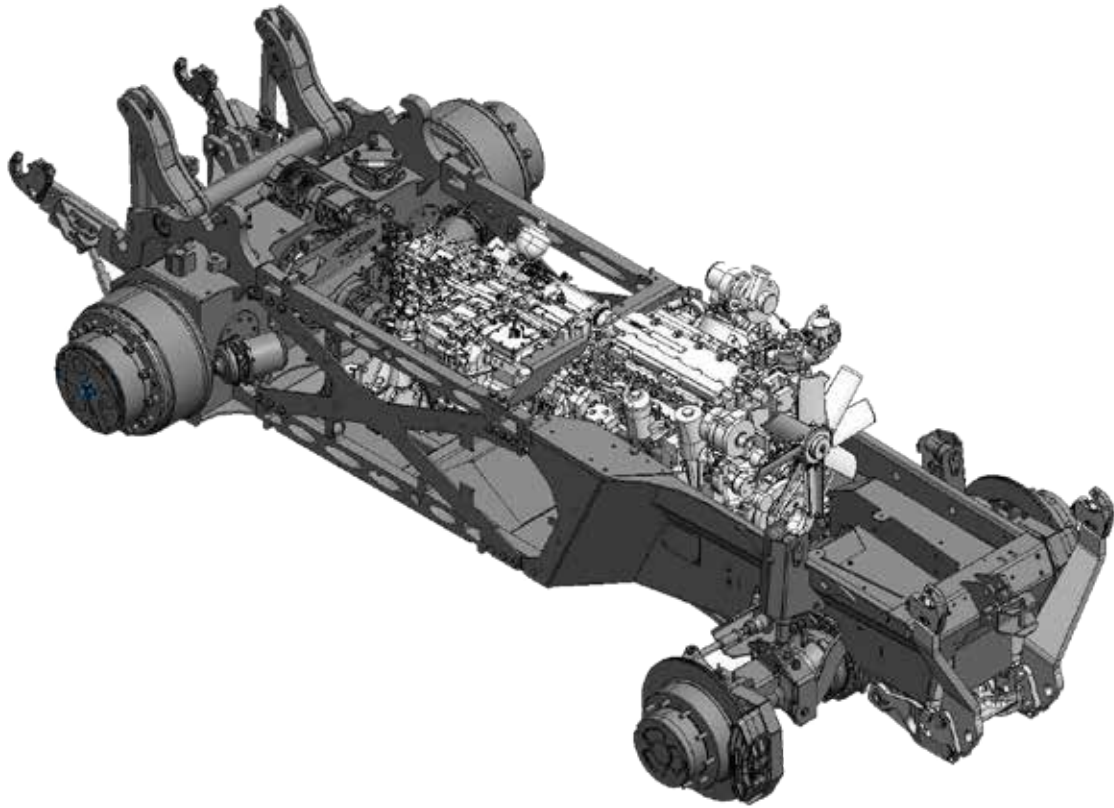

The chassis

The Pm Trac is not only energetic with its new bonnet design. The chassis has also undergone many further developments and new components have been used. The chassis is built over a frame in which the individual units are installed. The biggest change to the chassis concerns the transaxle. The transmission and rear axle unit was previously purchased from ZF. With the new series, Pfanzelt produce the unit themselves - the variaDRIVE transmission as well as a planetary-driven rear axle from Pfanzelt are used. The Pm Trac *Generation 38* is now based on an almost 100% Pfanzelt tractor chassis. This enables the complete adaptation of all components to heavy-duty use in forestry and as a multipurpose tractor. The days of using components from agricultural tractors are over. The Pm Trac plays in a new league.

variaDRIVE

The comfortable and powerful handling corresponds to that of familiar power-split transmissions. However, additional comfort is offered when changing the direction of travel. This operates more gently and quickly. In this way, it is comparable to that of a hydrostat. The transmission is also efficient and performance-oriented thanks to the three travel ranges in forward drive and two travel ranges in reverse drive.

- Top speed 40/50 km/h
- Motor gear management
- No switching of clutches in shunting mode up to approx. ± 7 km/h
- Reduction of the engine speed when the final speed is reached
- Individual preselection of maximum speed for special applications (for example, forestry milling)

4 Implement and mounting compartments

In addition to the rear mounting compartment which is positioned with a favourable centre of gravity above the rear axle, the Pm Trac has a three-point implement compartment on the front and rear. Optional front loader consoles are available.



- 1 Rear compartment
- 2 Rear three-point linkage
- 3 Front three-point linkage
- 4 Front loader console



Crane set-up and dismantling in detail
[youtube.com/pfanzeltTV](https://www.youtube.com/pfanzeltTV)

Pfanzelt system mount (PSA)

Due to the changed cabin position towards the middle of the vehicle, additional equipment can be placed in the rear body space using the Pfanzelt system mount (PSA). It is located directly above the rear axle and therefore optimally designed for the load and the vehicle's centre of gravity.

A special quick-change system allows the implements to be changed within a very short time without tools. The assembly or disassembly of the crane and winch takes less than 20 minutes.

Crane set-up/dismantling in less than 20 minutes

- Tool-free assembly and disassembly in less than 20 minutes
- One-man system
- PSA | Pfanzelt system mounting for winches and crane (optionally also as a universal base plate for other implements)
- Separate dismantling of crane and winch is possible

Road Travel

A roadworthy transmission technology and a standard road approval for 50 km/h allow the operator to approach or change locations quickly and without additional transport technology. The vehicle can also be driven on public roads in combination with a forwarding trailer or a trailer chopper.

The lighting system and fenders required for road travel can easily and quickly be converted for forestry operations. The four fenders, which are mounted as a pluggable system, are taken off the vehicle. The side indicators and front lights are concealed behind protective devices.



More hydraulic power

The Pm Trac's hydraulic system now has a standard capacity of 160 l/min at 210 bar, which can optionally be increased to 200 l/min. In addition, the new variaDRIVE transmission enables an additional power pack to drive high-performance implements via a direct power take-off. Depending on the power requirement, the power pack can deliver more than 100 kW drive power. For high efficiency and higher

hydraulic pressures, additional 180 l/min at 350 bar are possible in the closed system.



Forest protection

Pfanzelt's Pm Trac forest protection concept includes bumper guards for the cab, roof, and engine hood as well as complete protection for the chassis.





Serviceability

Pfanzen's well thought-out service concept begins with easy access for cleaning the radiators and engine compartment. For optimum accessibility to the rest of the aggregate compartment, the vehicle's cab can be tilted open. Dismantling the loading crane and winch releases the last part of the chassis. The base plate of the tractor can also be opened by a cable winch.



Stowage space

Useful and tidy space for a chainsaw, fuel canister, and other useful accessories is provided by a large tool box below the entrance to the vehicle cabin.



Well-being zone with a view



XXL comfort cabin

The pneumatically suspended, large-volume cab which was developed by Pfanzelt enables quiet and comfortable working with perfect all-round visibility. A new noise insulation concept allows quiet and vibration-damped operation during use, especially at high engine speeds.

- More than 7 m² of glass surface provide optimal view of the working environment and increase work safety
- The steering column can be easily folded away when working in the forest
- Relaxed, ergonomic seat position on the air-suspended operator's platform which can be electrically rotated by 340°
- Always within reach, all the controls, the pedals, and the touchscreen terminal rotate together with the seat





The machine software

The intelligent machine control system, which is operated via a touchscreen monitor on the seat, allows presettings to be stored for four operators. A Pfanzelt default user, which cannot be modified, is also stored.

An additional operating terminal for road travel is located next to the steering wheel. All important parameters are displayed there in the driver's best possible view.

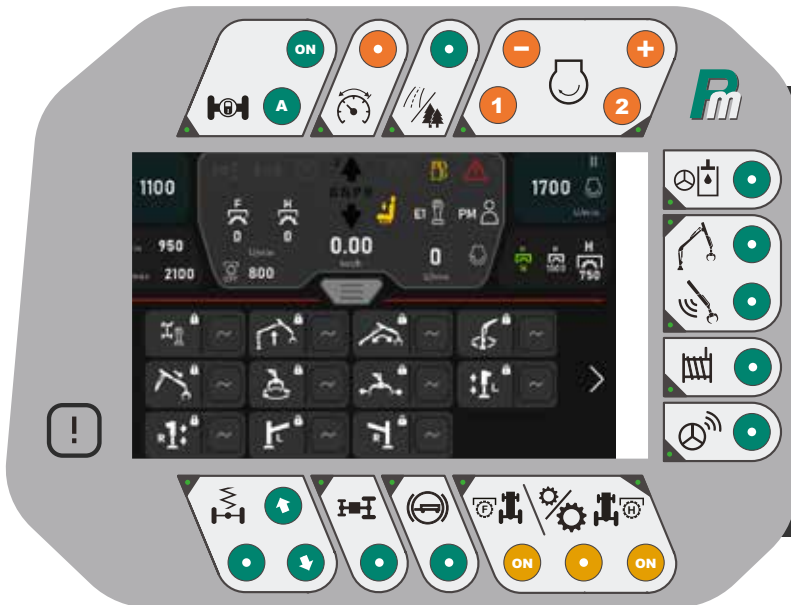

The new command centre on the rotating operator station

- Driver management for four drivers incl. individual assignment of joysticks and control levers
- Presets for hydraulic control units, crane functions, and auxiliary pumps
- PTO management
- Engine speed management
- Adjustment of the driving characteristics

Excerpt from the extensive menu navigation



Adapted to the driver; he can individually preselect the assignment of all joystick functions and operating levers for hydraulic control units at the operator station, and save them in the driver management system.



The hydraulic management allows pre-setting of all crane functions (including flow regulation, adjustment of characteristics of individual hydraulic functions and ramps).



In addition to the preselection of speed and start-up characteristic, an automatic switch-on and switch-off can also be pre-set in the PTO management.



Cranes for the Pm Trac *Generation 38*

The crane programme by Pfanzelt is one of the most extensive on the market. For the Pm Trac, modern and powerful professional cranes are available in different lifting classes from 5 to 7 mt and reaches up to 10 m. In addition to the technical specifications, the cranes also differ in their design.

Forwarding grapples and cranes

Pfanzelt has designed special cranes to be mounted on the Pm Trac. The two available series differ in terms of grapples and cranes. The former have a low crane column and are therefore specially designed for grinding long timber. Forwarding cranes, unlike forwarding grapples, have a high crane column and are optimised both for grinding long timber and loading a forwarding trailer with short timber.

Technical specs ► Page 104



Winches for the Pm Trac *Generation 38*



On the Pm Trac, Pfanzelt's winch units are mounted under the forest crane above the rear axle.

Double drum units with a pulling force of 6 or 8 t are available. Depending on the rope diameter and drum width, the maximum rope capacity is 150 metres. Pfanzelt uses multi-disc sinter plate packs for the exact control of braking and clutch operations. In order to avoid malfunctions of the hydraulic control, Pfanzelt's geared cable winch operates with a separate oil circuit with filter unit, which is fed by a hydraulic pump. The cable winch is operated either via an electric pushbutton control or a forestry radio system.

Technical details ► Page 24



Remote propel

In order to increase ergonomics during winch operation, the Pm Trac can also be equipped with an optional remote propel. When required, it can be activated simply by pressing a button on the display of the driver's station.

Short log forwarding with the 8-wheel Pm Trac

For combination with a Pm Trac, various Pfanzelt forwarding trailers are available for forwarding short timber. Requirements for modern forwarding trailers vary greatly depending on their application.

With a forwarding trailer with its own traction drive, the Pm Trac becomes a full-featured 8-wheel vehicle. This combination is on a par with a conventional forwarding combinations and also offers a wide range of other possible applications.

The 8-wheel system has a combined thrust of 16.1 tons. This allows demanding off-road driving with high ground protection. The drive speed of the forwarding trailer is optionally fully automatic, electronically controlled by the Pm Trac. Operator adjustments are possible if required. For example, a lead can be set.

For the combination with the Pm Trac, both the Profi forwarding trailers P17 and the logLINE back trailer L19 are appropriate.

The cable winch can be used even with the forwarding trailer attached. This makes it possible to rope logs outside the crane's reach and to carry out winch-assisted felling without any restrictions.



Forwarding trailers	P17	L19
Frame	Central tubular frame (300 x 200 x 10 mm)	Central tubular frame (350 x 250 x 8 mm)
Permissible total weight on public roads	17 t	19 t
Payload on private roads	15 t	17 t
Empty weight	approx. 2.5 t	approx. 3.5 t
Loading cross section/ length	3.52 m ² / 4,000 mm	3.5 - 4.0 m ² / 4,500 - 6,000 mm
Braking system	4-wheel pneumatic brake system	
Tyres	600/50-22.5 16 PR	600/50-22.5 16 PR
Drive system	powerDRIVE 4WD-II	powerDRIVE 4WD-II